



# IP-DMF

PoE+ INDOOR IP ENDPOINT WITH LCD DISPLAY,  
MICROPHONE, AND LED FLASHER

## TECHNICAL DATA SHEET



### KEY FEATURES

#### Network Features

- Dynamic or Static IP Address
- IEEE 802.3 10/100Base-T Ethernet
- IEEE 802.1q Tagging
- IEEE 802.3at Compliant

#### Audio Codec Support

- G.711 u-law / a-law (16 kbit/s)
- G.729 Wideband Audio (64 kbits/s)

#### Auto Registration

- SLP for Singlewire Applications
- DNS SRV for Singlewire Applications
- DHCP Option 72 for Syn-Apps / Intradio Applications
- IEDNet+ for AtlasIED Applications

#### Static Configuration

- HTTP GUI for Static Configuration

#### Audio Features

- Integrated Amplifier with two 8Ω outputs
- Aux Audio Line-In Balanced (2.8Vpp 10K)
- Aux Audio Line-Out Balanced (2.8Vpp 10K)
- Integrated Microphone Allows for Full-Duplex Paging Based on Software Platform
- Can send 1 Static Multicast Stream (Line-in or Mic to Multicast Out)
- Can listen up to 10 Static Multicast Streams

#### Visual Features

- High Resolution Multi-Color LCD Display for Time/Date and Scrolling Text
- Multi-Color LED Flashers for visual signaling and Adjustable flasher Pulse Rate for ADA Compliance
- Flasher Supports up to 25 InformaCast Priorities

#### Additional Features

- 2 General Purpose Inputs
- 1 Relay Output (2A @ 30 VDC)
- Phone / Night Loud Ringer
- External Power Supply Option

### PRODUCT SUMMARY

AtlasIED IP-DMF is an indoor wall mount IP endpoint with LCD display, integrated talkback microphone, and LED flasher. It complements the Unified Communications (VoIP Communications) investment, including on-premises and hosted infrastructure platforms. With the IP-DMF, information can be pushed to people or spaces beyond the limitations of desktop telephony communication, in large spaces of where visual messaging is required to overcome high ambient noise.

### APPLICATIONS

Model IP-DMF registers as a communication endpoint directly within Singlewire, AtlasIED, and Syn-Apps' notification applications. It supports audio and/or scrolling text alerts and visual signaling to enhance physical security while improving day-to-day communications through advanced alerting, bell schedules and pre-recorded & scheduled announcements. The IP-DMF leverages the WAN or LAN network architecture.

The IP-DMF contains a PoE+ powered amplifier that can support up to two analog 8" speakers that will enable the IP-DMF to support announcements or intercom.

When using Singlewire's InformaCast® or Syn-Apps Revolution® notification applications, the IP-DMF can have its LCD display background colors sync'd to InformaCast® text and audio notification profiles. Customers can now display default color styles set for normal, warning and emergency notifications sending clear communication during any event.

AtlasIED IP-DMF supports Call Manager publisher subscriber SIP Service call processing failover. This service provides remote location call-processing redundancy when access to the centralized Call Manager is interrupted because of a WAN outage. In a Cisco UMC environment,

IPX devices can register to either Cisco's basic or advanced 3rd Party SIP device service for intercom or paging functionality. IPX must use Cisco's Advanced 3rd Party SIP device service when registering to a publisher subscriber configuration.

Where 3rd party notification applications are not required, the IP-DMF can register as a SIP device directly to a SIP server or VoIP Communications Manager for critical alerts, intercom, and public address.

Under Title II of the Americans with Disabilities Act (ADA), all state and local governments are required to take steps and ensure effective communication to people with disabilities. The AtlasIED IP-DMF IP visual endpoint with optional speaker connectivity, LCD display, talkback microphone, and LED flasher provide effective communication for all individuals.

# IP-DMF

PoE+ INDOOR IP ENDPOINT WITH LCD DISPLAY,  
MICROPHONE, AND LED FLASHER

## TECHNICAL DATA SHEET



### AUDIO SPECIFICATIONS / PERFORMANCE

SYSTEM	
Type	PoE+ Indoor IP Endpoint with LCD Display and Microphone
Operation Temp.	-20°C (-4°F) to 55°C (131°F)
Indicators	Network Status (On Back)
General Purpose Interface	Two Trigger Inputs / One Relay Output (2A @ 30 VDC)
Amplification	40o (-6dB, 2000 Hz Octave Band)

AMPLIFICATION	
Type	Single-Channel Class D Topology with Primary and Secondary Outputs
AC Power Input	PoE+ and External 24VDC
Power Rating (RMS)	25 Watts Max (802.3at)
THD	<0.2%
Cooling	Passive / Convection

AMPLIFICATION	
Type	Single-Channel Class D Topology with Primary and Secondary Outputs
AC Power Input	PoE+ and External 24VDC
Power Rating (RMS)	25 Watts Max (802.3at)
THD	<0.2%
Cooling	Passive / Convection

MICROPHONE	
Sensitivity	Minus 35 (±4dB) / (0db = 1V/pa, 1kHz)
Impedance	Less than 2.2k <sup>Ω</sup>
Directivity	Omnidirectional
Frequency Range	20Hz – 20kHz
Standard Operation Voltage	2V
Max. Operation Voltage	10V
Current Consumption Max.	0.5 mA
Sensitivity Reduction Within	Minus 3dB @ 1.5V
S/N Ratio	More than 62dB

AUDIO INPUTS AND OUTPUTS	
Input: Analog Audio Type(s)	One Balanced Line Level
Input: Analog Connectivity	Secured Screw Terminal Block
Input: Network Audio Type(s)	G.711 U-Law / A-Law and G.722 Capable
Input: Multicast Permanent Stream	Registered Subscriber/s for up to 10 Different Streams
Input: Network Connectivity	RJ-45 Female
Output: Analog Audio Type(s)	One Balanced Line Level
Output: Multicast Permanent Stream	One Broadcast Using Line-In or Integrated Microphone *** Note: Audio Does Not Play out of the Sending Device***
Output: Analog Connectivity	Secured Screw Terminal Block
Output: Digital Audio Type(s)	G.711 U-Law / A-Law and G.722 Capable Multicast)
Output: Digital Connectivity	N/A

(CONTINUED ON NEXT PAGE)

# IP-DMF

PoE+ INDOOR IP ENDPOINT WITH LCD DISPLAY,  
MICROPHONE, AND LED FLASHER

## TECHNICAL DATA SHEET



### AUDIO SPECIFICATIONS / PERFORMANCE (CONTINUED)

Output: Speaker Level	8Ω, 25 Watts Max (802.3at)
Output: Speaker Connectivity	Two x Secured Screw Terminal Block

#### DISPLAY

Display Type	High Resolution Back-Lit Color LCD
Display Color Range	16 Million Color Options for Both Backlit Display and Text
Surface Lumens	1900 cd/m <sup>2</sup> Minimum, All White Pixels
Character Max Height	480 Pixels
Viewable Dimensions (HxW)	8.66" (221mm) x 2.23" (57mm)
Control	Time via NTP - Text Controlled via Software

#### FLASHER

Flasher Type	LED
Flash Color Range	Red, Green, Blue, Yellow, Teal, Purple, & White
Flasher Illuminance (lux)	83 Red, 545 Green, 90 Blue, 570 White
Flash Rate(s)	Adjustable flasher Pulse Rate
Viewable Dimensions (HxW)	0.5" (13mm) x 3.5" (89mm)
Control	Controlled via Software

#### SOFTWARE

GCK Compatible Version	7.0+
InformaCast Advanced Compatible Version	4.0+
InformaCast Fusion Compatible Version	3.0+
Intrado Revolution Compatible Versions	v2017.3.1+
SA-Announce Compatible Versions	9.0.18+

#### NETWORK

Ethernet	IEEE 802.3 10/100Base-T
PoE	IEEE 802.3 AT Compliant
VLAN	IEEE 802.1q Tagging

#### PROTOCOLS

IP Addressing	DHCP / Static
Auto-Registration	HTTP / Service Location Protocol / DNS SRV / IEDNet+ / DHCP Option 72 and Option 150
LLDP-MED	PoE Power Negotiation
Time	NTP
Telephony	SIP

(CONTINUED ON NEXT PAGE)

# IP-DMF

PoE+ INDOOR IP ENDPOINT WITH LCD DISPLAY,  
MICROPHONE, AND LED FLASHER



## TECHNICAL DATA SHEET

### AUDIO SPECIFICATIONS / PERFORMANCE (CONTINUED)

ENCLOSURE	
Color	White
Mounting / Rigging Provisions	4 x Screws, Optional Surface or Flush Mount Enclosures
Safety Agency Ratings	ETL Listed to Comply with 62368-1, CSA C22.2 #62368-1, IEC 62368-1 CB Scheme and FCC
Ingress Protection	N/A
Logo	Black and Silver
Product Dimensions (HxWxD)	13.88" x 7.75" x 1.73" (353mm x 197mm x 44mm)
Shipping Dimensions (HxWxD)	15.9" x 10" x 6" (404mm x 254mm x 152mm)
Net Weight - lbs	2.55 lb (1.16kg)
Shipping Weight - lbs	3.46lb (1.57kg)
WARRANTY COVERAGE	
Warranty Period	5 Year

#### NOTES:

1. Watts: All wattage figures are calculated using the rated nominal impedance.

# IP-DMF

PoE+ INDOOR IP ENDPOINT WITH LCD DISPLAY, MICROPHONE, AND LED FLASHER

TECHNICAL DATA SHEET



## DIMENSIONAL DRAWING

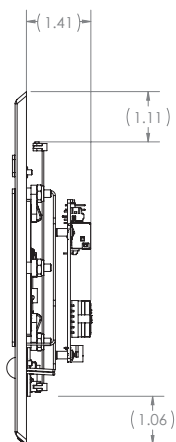
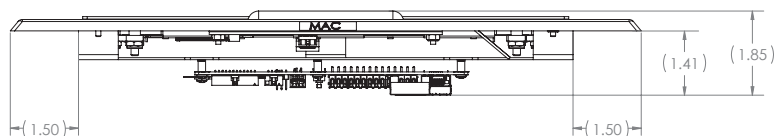
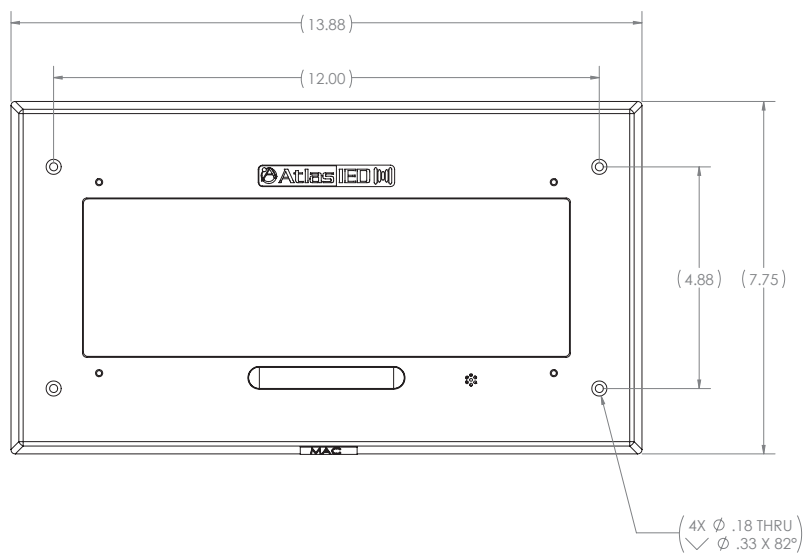

# IP-DMF

PoE+ INDOOR IP ENDPOINT WITH LCD DISPLAY, MICROPHONE, AND LED FLASHER

TECHNICAL DATA SHEET



## DIMENSIONAL DRAWING

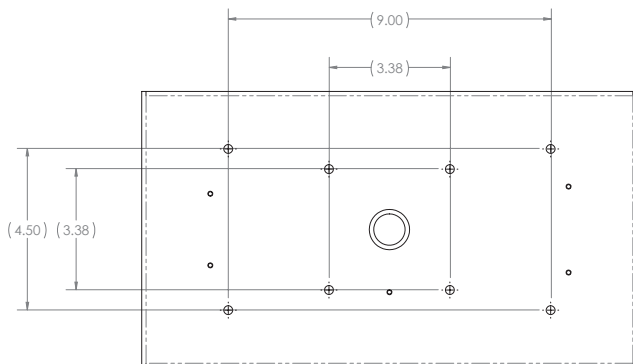
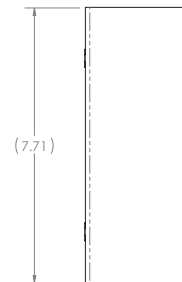
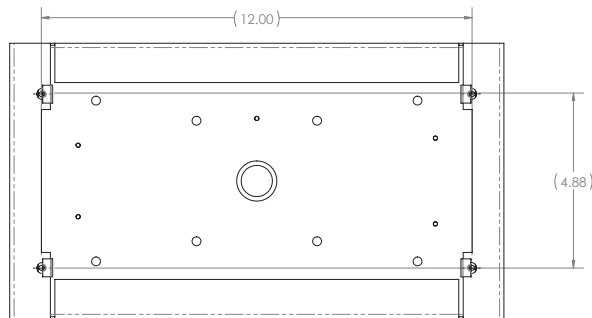
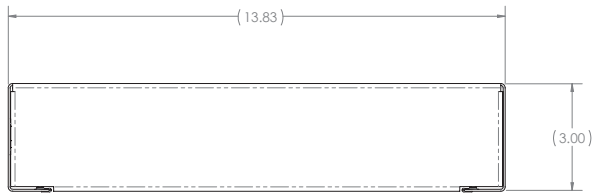
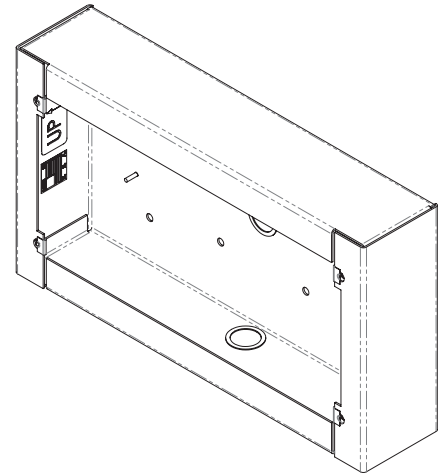

# IP-DMF

PoE+ INDOOR IP ENDPOINT WITH LCD DISPLAY, MICROPHONE, AND LED FLASHER

TECHNICAL DATA SHEET



## DIMENSIONAL DRAWING

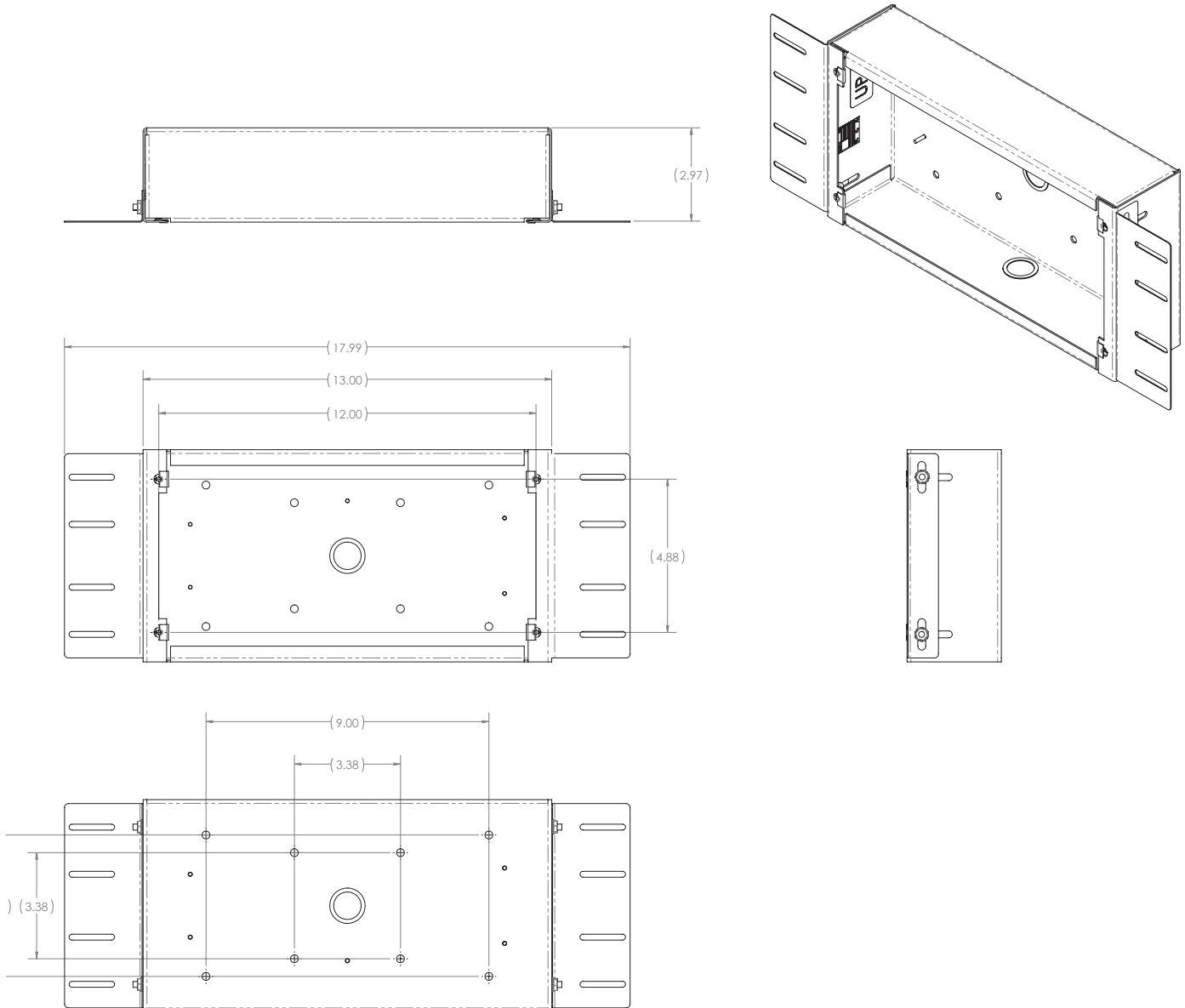

# IP-DMF

## PoE+ INDOOR IP ENDPOINT WITH LCD DISPLAY, MICROPHONE, AND LED FLASHER

### TECHNICAL DATA SHEET



### ARCHITECT AND ENGINEER SPECS

The unit shall be AtlasIED model IP-DMF. The PoE+ indoor IP endpoint visual system shall consist of a factory assembled IP addressable PCB amplifier / control, high-resolution multicolor LCD display, integrated microphone, and multicolor LED flasher.

The amplifier / control board shall receive announcements and messages using dynamically routed data on a standard Ethernet network. It shall include a single-channel class D topology amplifier with primary and secondary outputs capable of producing 25-watts RMS when using an IEEE 802.3at compatible PoE+ switch or 24VDC local power supply.

Interconnect shall be via female RJ-45 connector mounted to the PCB.

The amplifier / control board shall include (2) logic inputs, (1) relay output, (1) auxiliary balanced line level audio input and (1) balanced line level audio output. The auxiliary line level input shall include an auto mute function that is activated when a broadcast is sensed from the control application.

The amplifier / control board shall include a Graphical User Interface (GUI) for SIP configuration. The SIP implementation shall support standards G.711, G.722 and RTP protocols. The Graphical User Interface (GUI) shall configure and manage logic inputs, relay outputs, and Auxiliary audio input.

The unit shall incorporate a high-resolution backlit color LCD display with viewable dimensions of 8.66" (220.88mm) wide x 2.23" (56.72mm) high. It shall receive visual notifications via AtlasIED's GCK®, Syn-Apps' SA-Announce® and/or Revolution®, Singlewire's InformaCast® software platforms. It shall allow Singlewire's or Syn-Apps' custom display priority profile feature to automatically change its default background color to the user defined color styles while an alert is in progress. It shall display time and date when in standby mode from AtlasIED's GCK®,

Syn-Apps' SA-Announce® and/or Revolution®, Singlewire's InformaCast® software platforms or by NTP. The display shall produce 1900 cd/m<sup>2</sup> lux brightness and display text and/or time.

The unit shall incorporate an integrated microphone to allow full duplex talkback communication functionality based upon chosen software platform.

The unit shall incorporate an LED flasher with viewable dimensions of 0.5" (13mm) height x 3.5" (89mm) wide. The LEDs shall be able to produce RGB color spectrum with brightness of 83-lux (Red), 545-lux (Green), 90-lux (Blue), 570-lux (White). It shall have the capability of multi-speed flash rate and will be software controllable.

All control functionality shall be determined via software. It shall be compatible with AtlasIED's GCK®, Syn-Apps' SA-Announce® and/or Revolution®, Singlewire's InformaCast® software platforms and SIP standalone operation. The Indoor IP endpoint visual system overall dimensions shall be 13.88" (353mm) x 7.75" (197mm) x 1.85" (47mm) HxWxD. Finish shall be neutral white electrostatic powder coat.

#### Optional enclosures shall include:

- IP-SEC-DM:** Surface mount enclosure for IP-DM neutral white finish.
- IP-FEC-DM:** Flush mount enclosure for IP-DM reclaimed powder coat finish.